

WASTEWATER TREATMENT AND DISPOSAL OF INDIVIDUAL RESIDENTIAL BUILDINGS IN AGRICULTURE

Andrey Novikov^{1,2}, Anton Poddubsky³, Evgenii Dugin⁴, Olga Poddubskaya⁵,
Maksim Filimonov^{1,2}, Regina Gurina³

¹Volgograd State Technical University, Russia; ²Federal State Budget Scientific Institution the All-Russian research institute of irrigated agriculture, Russia; ³Peoples' Friendship University of Russia, Russia; ⁴Volgograd State Agricultural University, Russia; ⁵State University of Humanities and Technology, Russia
poddubskiy-aa@rudn.ru

Abstract. In the conditions of limited possibilities of traditional regulation of production processes in biogrocenoses it is necessary to find ways to increase their potential yield due to excessive man-made resources such as sludge from recycled wastewater. Ecological technologies of waste-free production, including the sludge sediment utilization as bio-fertilizer on agricultural fields, are a very promising direction of stabilizing the degradation processes of reducing soil fertility as well as increasing the moisture capacity, which is especially important for arid regions of the world. With the growth of suburban settlements the problem of high-quality wastewater treatment of individual buildings and, accordingly, the ecological well-being of these areas has become so urgent that it requires the development and creation of modern compact bio-cleaning modules, which should provide deep destruction of biogenic elements and possibility of secondary use of man-made resources without restructuring existing septic tanks and periodically exporting wastewater. In particular, it is a possibility to use purified water for irrigation of household plots or other technical needs, and to use sludge as a bio-fertilizer enriched with macro- and microelements. Ecological technologies of waste-free production, including the utilization of sludge from biological stations on agricultural fields as a bio-fertilizer, are very promising ways of stabilizing the degradation processes of reducing soil fertility in addition to increasing their water-holding capacity. Studies on the impact of various doses of the bio-fertilizer on the water-physical properties and the degree of soil contamination, as well as on the quality and yield of potato tubers cultivated for seed in the arid climate of the Lower Volga region confirmed its high efficiency and environmental friendliness.

Keywords: biological wastewater treatment, modular bio-station, sludge sediment, bio-fertilizer, drip irrigation, potatoes, seeds, water-physical properties of the soil, heavy metals, pollutants, environmental technology.

Introduction

In the conditions of limited possibilities of traditional regulation of production processes in biogrocenoses it is necessary to find ways to increase their potential yield due to excessive man-made resources such as sludge from recycled wastewater [1-4]. Ecological technologies of waste-free production, including the utilization of sludge sediment on agricultural fields as bio-fertilizer, is a very promising direction of stabilizing degradation processes of reducing soil fertility, as well as increasing its water-holding capacity, which is especially important for arid regions of the world [5-8].

The most effective of the known methods is the use of biological processes in wastewater treatment, since it provides not only their purification but also the removal of the biogenic elements nitrogen and phosphorus by freely floating biocenosis of activated sludge. However, the effective operation of biostations is achieved only with strict adherence to the technological process. The main difficulty in simultaneously removing nitrogen and phosphorus compounds from effluent is that their removal requires different conditions – nitrification and denitrification. Varying species and quantitative composition of microorganisms from the optimal value, for example, because of fluctuations in the initial concentrations of pollutants due to instantaneous emissions, a decrease in the concentration of dissolved oxygen, nutrients or an abrupt change in the pH of the medium can cause a change in the sedimentation characteristics of the activated sludge and a disruption of production – destruction processes in biocenosis [9-13].

At modern biostations wastewater treatment is carried out in several stages. As a result of passing the effluent through the full cycle of bioremediation, the output is conditionally purified water with the possibility of its secondary use, for example, for watering home gardens and other technical needs [14;15]. The problem of quality wastewater treatment of country houses and villages arose not so long ago, and as a result, local sewage systems became widespread, which are often “handicraft” and far from perfect because of their overall size, the need to restructure existing septic tanks and periodic removal

effluents, the impossibility of rational organization of biochemical processes of deep destruction of effluents and the secondary use of resources, including water [16;17].

In this regard, the aim of the work was to develop a module for biological treatment of household wastewater for individual residential buildings and to study the utilization of sludge sediment as a bio-fertilizer in potato cultivation in irrigated conditions of the Lower Volga region.

Materials and methods

To solve the aim a module was developed for biological wastewater treatment, which was mounted into an existing sealed septic tank. The module is a compact container with a sealed bottom, which is equipped with technological means. When the module is installed in a septic tank, a biostation is formed with two technological zones: the aeration tank and the secondary settling tank. The walls of the existing septic tank serve as a module casing, Fig. 1 [18;19].

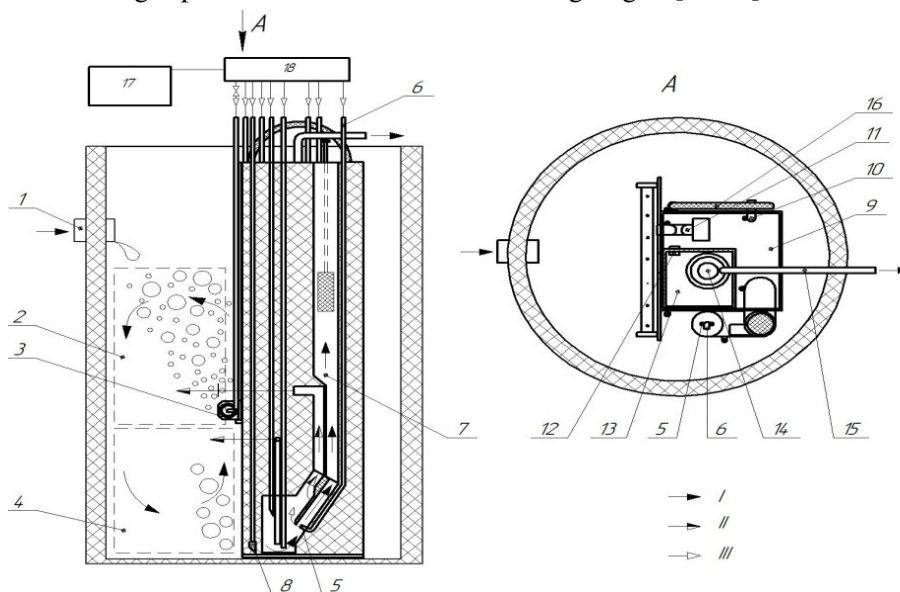

Fig. 1. **Modular biostation for wastewater treatment:** I – sludge mixture; II – air-sludge mixture; III – air; 1 – inlet nozzle 2 – aerobic zone; 3, 8 – aerators; 4 – anaerobic zone; 5 – blowing; 6, 11, 16 – airlifts; 7 – desilter; 9 – module housing; 10 – recirculation line; 12 – overflow pipe; 13 – clean water capacity; 14 – submersible pump; 15 – pressure pipeline; 17 – compressor; 18 – air distribution tank

The removal of excess activated sludge was made by airlift from the bottom part of the module anaerobic zone. Analytical studies of sludge after its pre-drying included the laboratory definition of toxicological, agrochemical, and sanitary-hygienic indicators for compliance with regulatory and technical documents [20;21].

Silt was disposed as a bio-fertilizer in the irrigated fields of the Lower Volga region in cultivation of potatoes for seed. To assess the effectiveness and environmental friendliness of the bio-fertilizer one-factor plotting experience was established for studying doses (at a rate of 20, 40 and 60 t·ha⁻¹) of bio-fertilizer for quantitative and qualitative indicators of potato tubers. Bio-fertilizers were applied to the field surface after the main tillage. In the control variant, instead of bio-fertilizers, complex mineral nutrition was applied with a dose of N₁₅₀ P₆₀ K₁₃₅, with phosphate and potash fertilizers applied under the main tillage, and nitrogen fertilizers were applied together with planting potatoes [22].

In the experiments we used the zoned variety “Arosa”, planting was carried out by the ridge method with a width of aisle of 0.7 m in the III decade of June at a rate of 70 thousand tubers per hectare, and harvesting potatoes was in the II – III decades of October [23;24].

Field experience in irrigation conditions was laid in accordance with existing methods [25;26], variants were placed systematically in fourfold, and data processing was performed by the method of

dispersion analysis. The landing plot area was 280 m^2 (2.8×100), and the registered one was 70 m^2 (2.8×25).

According to the phases of growth and development of potatoes depending on the weather conditions, diseases and pests, planting debris, traditional plant care activities were carried out.

Weather conditions were assessed by the Selyaninov hydrothermal coefficient (1) [27], which shows the moisture supply of the region by precipitation:

$$HTC = \left(10 \sum P\right) \cdot \sum t^{-1} \quad (1)$$

where P – precipitation for the period with the average daily temperature above $10 \text{ }^\circ\text{C}$, mm;

t – temperature over the same period, $^\circ\text{C}$;

$1.6 \leq SCC \leq 1.3$ – zone of sufficient moisture;

$1.3 \leq SCC \leq 1.0$ – weakly arid zone;

$1.0 \leq SCC \leq 0.7$ – arid zone;

$0.7 \leq SCC \leq 0.4$ – extremely dry zone;

$SCC < 0.4$ – zone with a dry climate.

Irrigation land reclamation is the limiting factor in the production of agricultural products in the arid conditions of the Lower Volga region, and drip irrigation is the most rational and resource-saving way to maintain the given humidity in the wetted soil layer. The pre-irrigation threshold of soil moisture was maintained at a level not lower than 80 % HB during the flowering phase in a layer of 0.4 m and 70 % HB in the remaining phases in a layer of 0.6 m [28-31].

The effectiveness of the bio-fertilizer was evaluated by the yield of potato tubers per seed, the ecological compatibility of the bio-fertilizer was evaluated by soil contamination Z (2) [32] and the quality of potato tubers for compliance with the standards [33]:

$$Z = \sum_{i=1}^n (C_i / C_{fi}) - (n - 1), \quad (2)$$

where n – number of components;

C_i – actual content of the i -th component in the soil, $\text{mg} \cdot \text{kg}^{-1}$;

C_{fi} – background content of the i -th component in the soil, $\text{mg} \cdot \text{kg}^{-1}$.

The determination of the qualitative indicators of potato tubers (heavy metals, starch, dry matter and nitrates) and heavy metals in the soil was carried out in an analytical laboratory. The content of organic matter was determined according to Tyurin [34-35], mobile forms of phosphorus and exchangeable potassium were determined according to Machigin [36], and easily hydrolyzed nitrogen – according to Tyurin and Kononova [35].

Water-physical properties of the soil were studied by standard methods: the density of addition was determined by the drilling method, the density of the solid phase by the pycnometric method, the natural humidity by the thermostatist – weight method, the lowest (field) moisture capacity by the method of flooded areas with sampling of soil samples for humidity after 48 hours. Soil samples were collected by a soil drill in fourfold repetitive ten-centimeter layers from the surface to a depth of one meter [37;38].

The soil is classified as chestnut by type, the subtype is light chestnut, and by its particle size distribution it is heavy loamy. The surface of the experimental area is without slopes, groundwater occurs at a depth of more than 5 m. The water-holding capacity of the soil is high, the meter layer can hold up to $2850 \text{ m}^3 \cdot \text{ha}^{-1}$.

The developed scheme of field experience allows us to give a comprehensive assessment of the effectiveness and environmental friendliness of the bio-fertilizer.

Results and discussion

Taking into account the experience of designing industrial biostations, a compact module, Fig. 1, has been developed for bioremediation of wastewater from individual residential buildings [18;19]. The aeration element 3, installed at a medium height outside the settler, divides the working volume of

the module into the upper (aerobic) 2 and lower (anaerobic) 4 zones, functionally creating a vertical-zonal aeration.

Conditions for nitrification and regeneration are created in the upper zone, and a denitrification zone is formed in the lower part. Large bubble aerators 8 are installed at the bottom part of the anaerobic zone for blending the sludge mixture.

Module housing 9 (functionally performing the work of the secondary clarifier) is made of polypropylene sheets and is a vertical container with a sealed bottom. Airlifts are installed to remove settled activated sludge and biofilm formed on the surface inside the settler. The anaerobic zone of the aerotank is connected to the secondary settling tank by the desilter 7. All the elements of the module are made of polymeric materials. The module is equipped with a mini-compressor 17 for the aeration system and air-lift operation. Air is supplied by the module elements through PVC hoses connected to the nozzles of technological elements in continuous mode through the air distribution tank 18. Stop valves are installed on the supply pipe to regulate the performance of the fine bubble aerator 3.

When the modular biostation is operating the effluent through the inlet nozzle 1 enters the oxidation zone 2 of the receiving chamber of the aerotank, where a high level of dissolved oxygen is maintained due to the vertically-stepped aeration. Under the action of the fine bubble aerator 3 in the receiving chamber not only the oxidation and decomposition of organic matter takes place, but also the regeneration of the sludge mixture coming from the secondary clarifier. Further the wastewater enters the anaerobic zone 4. Due to the lack of oxygen the biocenosis in the anaerobic zone begins to absorb oxygen from nitrites and nitrates formed in the oxidation zone.

The sludge mixture under the action of flow enters the desilter 7 through the air tube formed by the blowing 5 of the circulation airlift 6. Most of the sludge is retained and mixed with the help of a large bubble aerator 8 in the anaerobic zone.

The sludge mixture in the desilter passes through three successively installed chambers: a flow divider, a floating bio-load and a channel flow quencher. Under the action of air bubbles a swirling upward movement is formed in the flow divider. The partition is also installed here which allows to separate the vortex flow from the total flow, thereby carrying with it suspended substances into the recirculation channel directed into the aerobic zone. After passing through the flow divider the effluent passes through bio-loading along an upward trajectory which allows immobilizing activated sludge, keeping the slowly growing forms of microorganisms on itself. The resulting biofilm consisting of aerobic and anaerobic microorganisms creates an additional circuit after purification of residual contaminants.

Air is supplied to the upper part of the flow damper, the bubbles of which form a reverse countercurrent to the flow of water and partially repulse the sludge suspension from the damper returning them to bioloading. The three-stage sludge separator system allows to intensify the process of sludge separation and to increase the efficiency of wastewater treatment.

The accumulated sediment in the secondary settling tank is forcibly transferred via the recirculation line 10 to the aerobic zone, where in the pauses between the flow of effluent the activated sludge is regenerated. When applying wastewater, activated sludge is mixed with them providing a high oxidation rate of pollutants.

As a result of sedimentation a biofilm is formed on the surface of the secondary clarifier which is removed by a U – shaped airlift 11. Next the treated effluent enters the accumulative capacity of clean water 13 through the overflow pipe 12. A submersible pump 14 is installed in the accumulator, which automatically pumps water through the pressure pipeline 15 outside the modular biostation.

Excessive activated sludge (sludge sediment) is removed from the bottom part of the anaerobic zone by an airlift 16. It is absolutely harmless, it represents a complex organic-mineral bio-fertilizer saturated with macro- and microelements (Table 1), which is caused by its biological purification technology, ensuring the removal of nitrites and nitrates, as well as its deep mineralization.

To assess the soil of the experimental plot studies were conducted, the results of which showed that the total porosity and density of soil composition in the arable layer is 55.3 % and 1.25-1.29 kg·m⁻³, respectively. Down the profile the porosity decreases to 37.0 % and the density increases sharply to 1.40-1.44 kg·m⁻³. The moisture content of the steady wilting of plants in the

topsoil is about 9.6 %, with a decrease down the profile to 7.6 %. The reaction of the soil solution is slightly alkaline, pH of the aqueous extract varies from 7.2 to 7.6 units.

The density of the solid phase from the surface to the depth of one meter increases down the soil profile from 2.46 to 2.61 t·m⁻³, indicating the increase of solid particles in the soil, including mineral and organic components.

Table 1

Physical and chemical indicators of sludge after bioremediation of household waste

Monitored indicators	Values according to NTD	Actual value
pH salt, units	5.5-8.5	6.7
Moisture, %	< 70.0	35.0
Organic matter, %	> 20.0	15.0
Total nitrogen, %	> 0.6	2.54
Total phosphorus, %	> 1.5	4.2
Total potassium, %	> 0.1	1.25
Sulfur mobile, mg·kg ⁻¹	not normalized	1950.0
Mobile copper, mg·kg ⁻¹	not normalized	8.2
Mobile zinc, mg·kg ⁻¹	not normalized	35.0
Cobalt mobile, mg·kg ⁻¹	not normalized	0.18
Mobile manganese, mg·kg ⁻¹	not normalized	56.5
Pathogenic microflora	not allowed	missing
Heavy metals, mg·kg ⁻¹		
Lead	500.0	60.6
Cadmium	30.0	24.4
Mercury	15.0	0.20
Zinc	3500.0	553.9
Arsenic	20.0	3.0
Fluorine	10.0	2.56

The content of humus decreases down the profile from 2.20 % in horizon A to 0.88 % in horizon C. The composition of humus contains approximately equal amounts of humic and fulvic acids. The mobile forms of phosphorus are medium – 15 mg·kg⁻¹, exchangeable potassium is high – more than 340 mg·kg⁻¹, low-hydrolysable nitrogen is low – 43 mg·kg⁻¹.

The content of easily soluble salts is insignificant and safe for cultivation of potatoes, their amount from the surface to the depth of one meter increases, respectively chlorides – from 0.067 to 0.103 %, sulfates – from 0.0028 to 0.007 %.

Thus, the data obtained correlate with the previous studies [39, 40], the soil of the experimental plot is typical for the zone of the Lower Volga region and is suitable for growing potatoes for seed.

The formation of reserves of productive moisture and the choice of the irrigation regime of potatoes were influenced by the precipitation and temperature conditions, the graphical interpretation of which is shown in Fig. 2. The observation period (from June to September) in terms of heat availability was close to the average long-term values, planting potatoes were provided with heat until full maturity.

The distribution of precipitation was uneven. From May to September the precipitation fell was about 183 mm and taking into account the sum of temperatures for May 471 °C the hydrothermal coefficient was only 0.59, which characterizes the study area as extremely dry. Moreover, precipitation due to rain showers with high intensity did not provide soaking of deep layers and for the most part was spent on runoff and evaporation by the soil itself.

In conditions of insufficient natural moisture the share of irrigation water in the total water consumption of potatoes was 50.5 % or 2200 m³·ha⁻¹. The share of precipitation in the structure of total water consumption of potatoes was 42.1 % or 1830 m³·ha⁻¹ and the use of soil moisture reserves – 7.4 % or 320 m³·ha⁻¹. In general there were 12 vegetative irrigations with the norm from 110 to 290 m³·ha⁻¹, and the total water consumption of potatoes was 4350 m³·ha⁻¹.

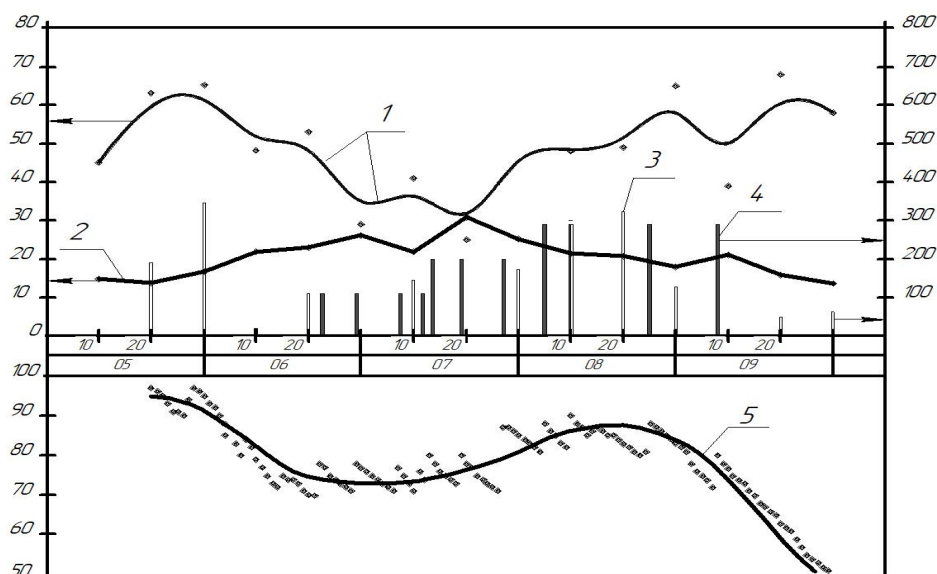

Fig. 2. Drip irrigation regime, climatic conditions and soil moisture in control potato plantations:
 1 – relative air humidity, %; 2 – air temperature, °C; 3 – total precipitation per decade $\text{m}^3 \cdot \text{ha}^{-1}$;
 4 – irrigation rates, $\text{m}^3 \cdot \text{ha}^{-1}$; 5 – moisture distribution in soil, % HB

The results of observations of humidity W (%) and density of soil composition ρ ($\text{t} \cdot \text{m}^{-3}$) according to the experimental options in a layer of 0.0-0.3 m before planting (in the numerator) and before harvesting (denominator) of potatoes are presented in Table 2.

Table 2

Layer Soil, m	Average values of water-physical properties of the soil							
	Options for doses of fertilizers, $\text{t} \cdot \text{ha}^{-1}$							
	Control		20		40		60	
	W	ρ	W	ρ	W	ρ	W	ρ
0.0-0.1	16.2	1.24	16.5	1.23	17.4	1.22	18.8	1.21
	12.8	1.27	13.0	1.27	13.0	1.26	13.5	1.25
0.0-0.2	16.3	1.24	16.5	1.23	17.4	1.22	18.8	1.21
	12.8	1.28	13.0	1.27	13.0	1.26	13.5	1.25
0.0-0.3	16.3	1.26	16.6	1.25	17.2	1.23	18.7	1.22
	12.3	1.30	12.7	1.30	12.8	1.28	13.2	1.27

Studies of the moisture content and density of soil composition by layers, Table 2, show their change depending on the doses of bio-fertilizer applied. The lowest soil moisture is noted at the control, where before planting potatoes in a layer of 0.0-0.3 m the indicator changes from 16.2 to 16.3 %, and before harvesting it varies from 12.8 to 12.3 %, in variants with bio-fertilizer the soil moisture rises with increasing the dose. So, before planting it increases from 16.5-16.6 % at $20 \text{ t} \cdot \text{ha}^{-1}$ to 18.8-18.7 % at $60 \text{ t} \cdot \text{ha}^{-1}$ and before harvesting at the same doses it increases from 13.0-12.8 % to 13.5-13.2 %. This proves the presence of sludge sorption properties in relation to moisture due to the structure of sludge, which is an accumulation of microorganisms with a total surface of about 100 m^2 per gram of dry matter [5-8].

The results of statistical processing of the data array of the dependence of W on the doses of biofertilizer application by layers for the accepted 5 % level of significance show that all differences are significant, however, there are both significant (before planting potatoes) and insignificant differences (after harvesting potatoes) between the options. This trend after harvesting potatoes is mainly due to the soil drying because of the cessation of irrigation and slight precipitation in September – it is about 11 mm at a sum of temperatures of 507 °C, Fig. 2, and leveling the humidity in layers. So, before planting a crop with a dosing rate of $20 \text{ t} \cdot \text{ha}^{-1}$ the soil moisture in the layers 0.0-0.1, 0.1-0.2, 0.2-0.3 m exceeds the control respectively by 0.3 % (NDS₀₅ = 0.15-0.22 %). With increasing dose the difference between the options becomes more significant: with a dose of $40 \text{ t} \cdot \text{ha}^{-1}$ – 0.9-1.2 %, with a dose of $60 \text{ t} \cdot \text{ha}^{-1}$ – 2.4-2.6 %.

A radically opposite pattern is observed with the density of the soil. Its greatest value is fixed at the control, where before planting potatoes in a layer of 0.0-0.3 m the indicator changes from 1.24 to 1.26 t·m⁻¹, and before harvesting – from 1.27 to 1.30 t·m⁻¹. With the introduction of bio-fertilizer, ρ somewhat decreases: before planting potatoes in layers 0.0-0.1 and 0.1-0.2 m from 1.23 to 1.21 t·m⁻¹, in layer 0.2-0.3 m from 1.25 to 1.22 t·m⁻¹; before harvesting potatoes – in layers of 0.0-0.1 and 0.1-0.2 m from 1.27 to 1.25 t·m⁻¹, in a layer of 0.2-0.3 m from 1.30 to 1.27 t·m⁻¹, respectively with an increase in the dose from 20 t·ha⁻¹ up to 60 t·ha⁻¹. This trend for a short observation period indicates an increase in the soil content of agronomically valuable and water-resistant fractions of more than 0.25 mm in size when sludge is introduced, which allows to characterize it not only as a bio-fertilizer saturated with macro and microelements, but also ameliorating soil structure.

The results of statistical processing of the data array of the dependence of ρ on the doses of bio-fertilizer applied by layers for the accepted 5 % level of significance are heterogeneous, there are both significant and insignificant differences between the options. Significant differences in the density of soil composition are observed in the variants with doses of 40 and 60 t·ha⁻¹ for layers 0.1-0.2 and 0.2-0.3 m.

So, before planting potatoes, ρ in layers of 0.1-0.2 and 0.2-0.3 m in variants with a dose of 40 and 60 t·ha⁻¹ bio-fertilizer is lower than in control, respectively, by 0.02-0.03 t·m⁻³ and 0.03-0.04 t·m⁻³ (HCP05 = 0.017; 0.014 t·m⁻³). Before harvesting significant results are observed only in the variant with a dose of applying bio-fertilizer 60 t·ha⁻¹ in the layer of 0.0-0.3 m the density of soil composition is 0.02-0.03 t·m⁻³ lower than in the control (HCP05 = 0.014-0.023 t·m⁻³).

The content of gross forms of heavy metals is a factor of capacity reflecting the potential danger of contamination of plant products, infiltration and surface water, but does not reflect the degree of availability of elements for plants. According to the degree of danger of pollutants exposure on the soil class 1 includes chemicals Cd, Pb, Zn, As, Hg, Se, F and C20H12 [32]. Taking into account the chemical composition of the sludge deposit (Table 1), observations were made of the dynamics of the entry of heavy metals — cadmium, lead, zinc, and copper (element 2 of hazard class) into the soil, Table 3, and potato tubers, Table 4.

Table 3

Characteristics of gross forms of heavy metals in the topsoil

Heavy metals	Permissible concentration, mg·kg ⁻¹		Concentrations in the variants according to the doses of fertilizers, mg·kg ⁻¹			
	MPC	JDC	Control	20 t·ha ⁻¹	40 t·ha ⁻¹	60 t·ha ⁻¹
Cd	1.0	2.0	0.16	0.39	0.40	0.59
Pb	65.0	130.0	16.0	16.21	17.5	17.7
Zn	110.0	220.0	44.0	44.4	45.43	46.32
Cu	65.0	132.0	16.0	16.27	17.37	17.98

Table 4

Qualitative and quantitative indicators of potato tubers

Options for doses of fertilizers	Heavy metals, mg·kg ⁻¹				Y, t·ha ⁻¹	Starch, %	Nitrates, mg·kg ⁻¹ (250)	Dry matter, %
	Cd (0.03)	Pb (0.5)	Zn (10.0)	Cu (5.0)				
Control	0.015	0.81	7.97	5.65	20.6	12.64	35.7	20.32
20 t·ha ⁻¹	0.016	0.82	8.86	6.07	21.9	12.96	36.0	20.45
40 t·ha ⁻¹	0.020	0.84	10.47	6.54	23.7	13.32	137.0	21.46
60 t·ha ⁻¹	0.024	0.87	11.14	7.07	26.4	14.24	227.0	22.54

The degree of soil contamination of the experimental site with heavy metals was determined by comparing it with the maximum permissible concentration (MPC) and the approximate permissible concentration (APC) of the corresponding pollutant or its background content, as well as the pollution index Z [32]. Analysis of the data in Table 3 shows that all the observed elements in the topsoil do not exceed the MPC and APC. Soil pollution index varies from 2.5 units at a dose of biofertilizer 20 t·ha⁻¹

to 4.0 units, respectively, at a dose of $60 \text{ t}\cdot\text{ha}^{-1}$. When $Z < 16$ the soil belongs to the category with acceptable contamination.

The chemical composition of plants reflects the elemental composition of the soil. Therefore, the excessive accumulation of heavy metals by potato tubers is due to their concentration in soils, as well as by non-root absorption from air currents. The quality of potato tubers depends on the content of starch, dry matter and nitrates. Products are considered to be of high quality, when the starch content is from 10 to 24 %, dry matter from 20 to 30 % and nitrates not more than $250 \text{ mg}\cdot\text{kg}^{-1}$. Relatively to heavy metals, products are considered “clean”, when they are below the MPC, “conditionally suitable” – above the MPC, but not more than 2 MPC, unfit – more than 2 MPC [33].

According to the data obtained, potato tubers in terms of starchiness, nitrates and dry matter (Table 4) are related to quality products, and relatively to heavy metals, to “pure” and “conditionally suitable” products. At the same time, taking into account the seed orientation of potato tuber production, the presence of pollutants in the range from MPC to 2 MPC is further leveled when growing commercial potatoes.

The effectiveness of bio-fertilizers was evaluated by the yield of potato tubers Y (Table 4). According to the results of statistical data processing it is obtained that all differences are significant. The yield of potato tubers in options with doses of bio-fertilizer 20, 40 and $60 \text{ t}\cdot\text{ha}^{-1}$ exceeds the control variant, respectively, by 1.35, 3.15 and $5.85 \text{ t}\cdot\text{ha}^{-1}$ ($\text{HCP05} = 0.74 \text{ t}\cdot\text{ha}^{-1}$) or by 6.3, 15.0 and 28.2 %.

Conclusions

The use of modern compact modules for biological treatment of domestic wastewaters of individual residential unable to connect to centralized sewage systems allows not only to improve the ecological well-being of suburban settlements, but also to reuse water for irrigation of household plots or other technical needs, and also to use sludge as a source of macro-and micronutrient nutrition of agricultural crops. The bio-fertilizer based on deeply mineralized sludge has sorption properties, increases the number of agronomically valuable and water-resistant aggregates, and is environmentally safe for soil and plants. The use of the bio-fertilizer is especially important in conditions of hydrothermal climatic tension, since the moisture sorbed and retained by sludge stimulates the germination and vegetation of crops.

Acknowledgments

The publication has been prepared with the support of the “RUDN University Program 5-100”.

References

- [1] Asadu CO, Aneke NG, Egbuna SO et al. Comparative studies on the impact of bio-fertilizers produced from agro-wastes using a thermostimulate-freezing agent and Zee-mays and Okro (*Abelmoschus esculentus*) // *Environmental Technology and Innovation*. 2018. Vol. 12. pp. 55-71.
- [2] Cucina M., Tacconi C., Ricci A. et al. Evaluation of the use of organic wastes of organic origin // *Science of the Total Environment*. 2018. Vol. 613-614. pp. 773-782.
- [3] Lee LH, Wu TY, Shak KPY et al. Teoh Sustainable approach to biotransform industrial sludge into organic fertilizer via vermicomposting: a mini-review // *Journal of Chemical Technology and Biotechnology*. 2018. Vol. 93, Issue 4. pp. 925-935.
- [4] Melo W., Delarica D., Guedes A. et al. Ten years of application of sewage sludge on tropical soil. *AGRICULTURE OF A GLOBAL ENVIRONMENT*. 2018. Vol. 643. pp. 1493-1501.
- [5] Пындак В. И., Новиков А. Е. Природные мелиоранты на основе кремнеземов и глиноземов // *Известия Нижневолжского агроуниверситетского комплекса: Наука и высшее профессиональное образование*. 2015. № 2 (38). С. 73-76. (Natural ameliorants based on silica and alumina) (In Russian)
- [6] Зволинский В. П., Пындак В. И., Тютюма Н. В. и др. Проблемы и перспективы выращивания технических культур в засушливых условиях Заволжья // *Известия Нижневолжского агроуниверситетского комплекса: Наука и высшее профессиональное образование*. 2014. № 4 (36). С. 176-179. (Problems and Prospects of Cultivation of Industrial Crops in Dry Conditions of the Volga Region) (In Russian)

- [7] Пындак В. И., Новиков А. Е., Степкина Ю. А. Решение проблем отходов и плодородия деградированных земель (на примере Нижнего Поволжья) // Научное обозрение. 2013. № 4. С. 85-89. (Solution of the problems of waste and fertility of degraded lands (on the example of the Lower Volga region) (In Russian)
- [8] Pyndak VI, Novikov AE, Shtepa VN Optimization of organic-containing wastewater and sludge treatment systems // Journal of Machinery Manufacture and Reliability. 2017. Vol . 37, No . 4. pp. 507-511.
- [9] Возная Н. Ф. Химия воды и микробиология. М.: Высш. школа, 1979. 340 с. (Water chemistry and microbiology) (In Russian)
- [10] Новиков А. Е., Дугин Е. А., Филимонов М. И. Адаптация биоценоза активного ила к сульфидиону в модельных сточных водах // Известия Нижневолжского агроуниверситетского комплекса: Наука и высшее профессиональное образование. 2018. № 4 (36). (Adaptation of the biocenosis of active sludge to sulfide-ion in model wastewater) (In Russian)
- [11] Пындак В. И., Чернова Ю. А., Дугин Е. А. и др. Модернизация и снижение энергоемкости станций очистки сточных вод // Ремонт. Восстановление. Модернизация. 2016. № 6. С. 27-29. (Modernization and reduction of energy intensity of wastewater treatment plants) (In Russian)
- [12] Жмур Н. С. Технологические и биохимические процессы очистки сточных вод на сооружениях с аэротенками. М.: АКВАРОС, 2003. 512 с. (Technological and biochemical processes of wastewater treatment at buildings with aeration tanks) (In Russian)
- [13] Воронов Ю. В., Яковлев С. В. Водоотведение и очистка сточных вод. М.: Изд-во Ассоциация строительных вузов, 2006. 704 с. (Wastewater disposal and sewage treatment) (In Russian)
- [14] Gross M., Dee M. Septic Tank Effluent // ASAE Publication. 1985. pp. 295-304.
- [15] Шуравилин А. В., Овчинников А. С., Сурикова Н. В. и др. Эффективное использование сточных вод и их осадка для орошения и удобрения сельскохозяйственных культур: монография. Волгоград: «Нива», 2009. 636 с. (Effective use of wastewater and their sediment for irrigation and fertilization of agricultural crops: monograph) (In Russian)
- [16] Haydar S., Anis M., Hina GE et al. Developed countries for developing countries // Chinese Journal of Chemical Engineering. 2018. 26 (4), pp. 886-891.
- [17] Bunce JT, Ndam E., Ofiteru ID et al. Frontiers in Environmental Science. A review of phosphorus removal technologies and their applicability to small-scale domestic wastewater treatment systems. 2018. Vol . 6, No. eight.
- [18] Патент RU173043 Устройство биоочистки / В. В. Ясакин, Е. А. Дугин, В. И. Пындак и др. Оpubл. 08.08.2017. Patent RU 173043 A device for bioremediation / V.V. Yasakin, E.A. Dugin, V.I. Pyndak et al. Publ. 08.08.2017 (In Russian)
- [19] Патент RU173044 Устройство биологической очистки сточных вод / В. В. Ясакин, Е. А. Дугин, В. И. Пындак и др. Оpubл. 08.08.2017. Patent RU 173044 Device for biological wastewater treatment / V.V. Yasakin, E.A. Dugin, V.I. Pyndak, et al. Publ. 08.08.2017 (In Russian)
- [20] ГОСТ Р 54651-2011. Удобрения органические на основе осадков сточных вод. Технические условия. УТВ. 13.12.2011. (GOST R 54651-2011. Organic fertilizers based on sewage sludge. Technical conditions. Approved 12/13/2011) (In Russian)
- [21] ГОСТ Р 17.4.3.07-2001. Охрана природы (ССОП). Почвы. Требования к свойствам осадков сточных вод при использовании в качестве удобрений. УТВ. 23.01.2001. (GOST R 17.4.3.07-2001. Nature Conservation (MTS). Soils. Requirements for the properties of sewage sludge when used as fertilizer. Approved 01.23.2001) (In Russian)
- [22] Филин В. И. Справочная книга по растениеводству с основами программирования урожая. Волгоград: ВГСХА, 1994. 266 с. (Reference book on crop production with the basics of crop programming) (In Russian)
- [23] Патент RU2435361 Способ возделывания картофеля летними посадками на орошаемых землях в условиях юга России, преимущественно для зон с рискованным земледелием / В. В. Мелихов, А. А. Навитная, П. И. Кузнецов и др. 10.12.2011 (Patent RU 2435361 Method of potato cultivation by summer planting on irrigated land in the conditions of southern Russia, mainly for areas with risky farming / V.V. Melikhov, A.A. Navitnyaya, P.I. Kuznetsov and others. Publ. 10.12.2011) (In Russian)

- [24] Патент RU2430507 Способ возделывания картофеля преимущественно для зон с рискованным земледелием / И. В. Дергачева, А. А. Навитня, Д. В. Козлов и др. Опубл. 10.10.2011 (Patent RU 2430507 Method of potato cultivation mainly for areas with risky agriculture / I. V. Dergacheva, A. A. Navitnyaya, D. V. Kozlov, etc. Publ. 10.10.2011) (In Russian)
- [25] Плешаков В. Н. Методика полевого опыта в условиях орошения: рекомендации // ВНИИОЗ. Волгоград, 1983. 150 с. (Methods of field experience under irrigation: recommendations) (In Russian)
- [26] Доспехов Б. А. Методика полевого опыта (с основами статистической обработки результатов исследования). М.: Агропромиздат, 1985. 351 с. (Methodology of field experience (with the basics of statistical processing of research results) (In Russian)
- [27] Селянинов Г. Т. Методика сельскохозяйственной характеристики климата // Мировой агроклиматический справочник. Л.: Гидрометеиздат, 1937. С. 5-27 (Methods of agricultural characteristics of climate) (In Russian)
- [28] Мелиорация и водное хозяйство. Орошение: справочник / И. П. Айдаров, К. П. Арент, В. Н. Басс и др.; под ред. Б. Б. Шумакова. М.: Изд-во «Колос», 1999. 432 с. (Land improvement and water management. Irrigation: a reference book) (In Russian)
- [29] Дубенок Н. Н., Болотин Д. А., Болотин А. Г. Продуктивность различных сортов картофеля при капельном орошении в Нижнем Поволжье Известия Нижневолжского агроуниверситетского комплекса: Наука и высшее профессиональное образование. 2017. № 2 (46). С. 28-37. Efficiency of different varieties of potatoes with drip irrigation in the Lower Volga Region) (In Russian)
- [30] Li F., Liang X., Chen K. The Advanced Materials Research. 2013. Vol. 684. pp. 242-245.
- [31] Salimov FN Remarks on the introduction of irrigation technology in Azerbaijan // Journal of Water and Land Development 2012. Vol . 16, Issue 1. pp. 55-59.
- [32] МУ 2.1.7.730-99 Гигиеническая оценка качества почвы населенных пунктов. Утв. 05.02.1999.(МУ 2.1.7.730-99 Hygienic assessment of the quality of the soil settlements. Approved 02/05/1999) (In Russian)
- [33] СанПиН 2.3.2.1078-01 Гигиенические требования к безопасности и пищевой ценности пищевых продуктов. Утв. 01.07.2002. SanPiN 2.3.2.1078-01 Hygienic requirements for the safety and nutritional value of food. Approved 07/01/2002. (In Russian)
- [34] ГОСТ 26213-91 Почвы. Методы определения органического вещества. Утв. 29.12.1991 (GOST 26213-91 Soils. Methods for the determination of organic matter. Approved 12/29/1991) (In Russian)
- [35] Агрохимические методы исследования почв. М.: «Наука», 1975. 656 с. (Agrochemical methods for soil investigation) (In Russian)
- [36] ГОСТ 26205-91 Почвы. Определение подвижных соединений фосфора и калия по методу Мачигина в модификации ЦИНАО 29.12.1991 GOST 26205-91 (Soils. Determination of mobile compounds of phosphorus and potassium according to the method of Machigin in the modification of TsINAO (In Russian)
- [37] Вадюнина А. Ф., Корчагина З. А. Методы исследования физических свойств почв. М.: Агропромиздат, 1986. 416 с. (Methods for studying the physical properties of soil) (In Russian)
- [38] ГОСТ 28268-89 Почвы. Методы определения влажности, максимальной гигроскопической влажности и влажности устойчивого завядания растений 27.09.1989. (GOST 28268-89 Soils. Methods for the determination of moisture, maximum hygroscopic moisture and moisture resistant wilting of plants)(In Russian)
- [39] Микитин С. В., Шуравилин А. В., Бородычев В. В. и др. Влияние обработки почвы и минерального питания на динамику биологической активности и NPK при возделывании ярового ячменя // Вестник Российского университета дружбы народов. Серия Агрономия и животноводство. 2017. Т. 12, № 4. С. 295-304. (Effect of tillage and mineral nutrition on the dynamics of biological activity and NPK in the cultivation of spring barley) (In Russian)
- [40] Шуравилин А. В., Бородычев В. В., Поддубский А. А. Урожайность ярового ячменя на каштановой почве Нижнего Поволжья // Вестник Российского университета дружбы народов. Серия: агрономия и животноводство. 2016. № 2. С. 7-14. (Spring barley yields on chestnut soil in the Lower Volga region) (In Russian)